

FEATURES:

Waterproof XXL-Stopwatch for under-water operation

- Self-control by simply pressing on the large display
- Dual Time (12/24 hr.) and Date-Function
- Alarm function (3 settings possible)
- Stopwatch with lap function
- Lap counter (50 memories)
- Lap timer and pacer
- Best challenger (Displays the 3 best lap times)
- Displays calories burnt on Free-Style, Back Stroke, Breast Stroke and Butterfly
- Super bright LED indicator
- LED-backlight
- Including detachable suction cups for attachment inside swimming pool
- Including detachable cord



- Lap Chrono function indicator
- Lap Counter function indicator
- Lap Timer function indicator
- PACE - Lap Pace Chrono function indicator
- BEST - Best Challenger function indicator
- Data mode indicator
- Daily alarm enable indicator
- Keytone enable indicator

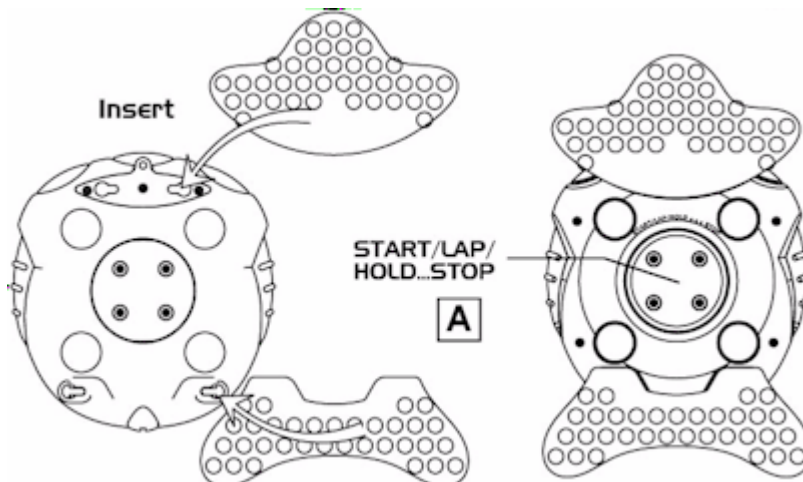
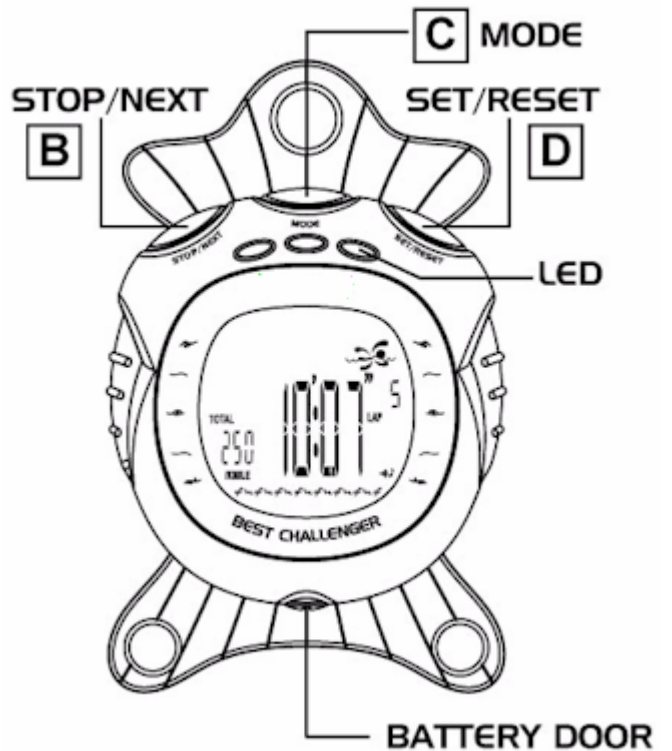

In order to make the most out of XXL-Swim Control, there are four ways of attaching it in the pool.

1. If you are swimming in a standard pool where the water level is not full. It is recommended to stick the XXL-Swim Control above water. It is because you could see the lap time and red L.E.D. indicator more easily as well as the alarm alert system. (see drawing 1)
2. If you are swimming in a pool where the water level is full and it is suggested to stick at the edge of the pool. (see drawing 2)
3. It can also be stick underwater since it is water resistance but we recommend our first two suggestions for using and getting the best performance out of it (see drawing 3)

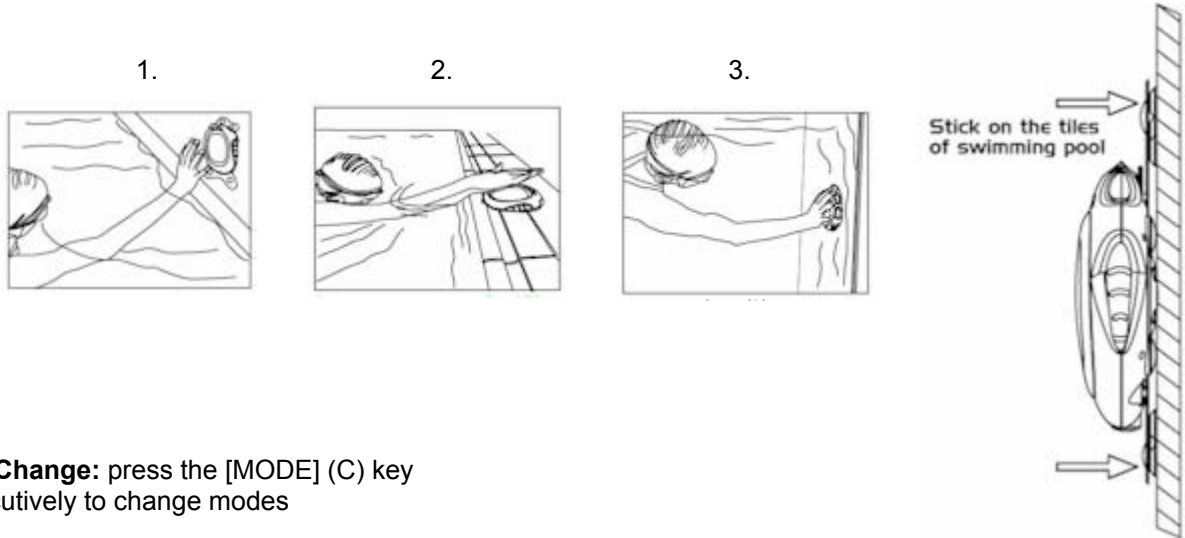

Mode Change: press the [MODE] (C) key consecutively to change modes

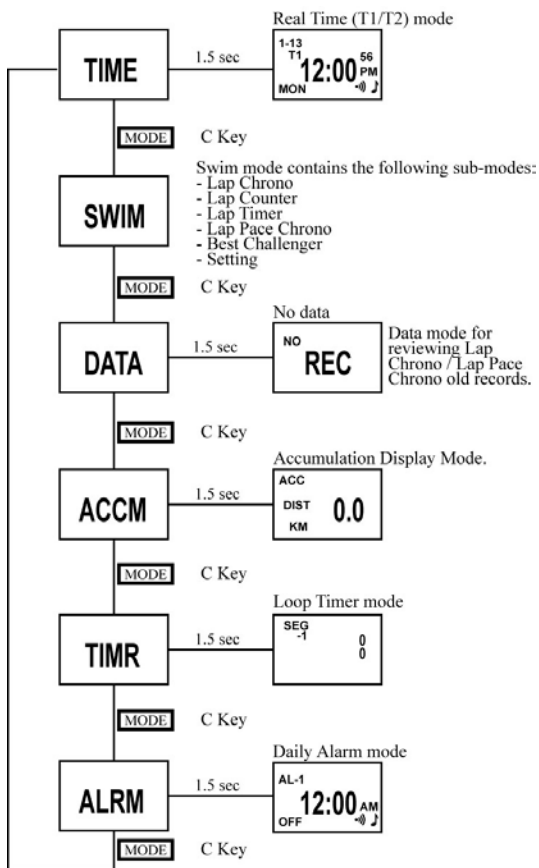

SWIM MODE (sub-mode change)
Press [STOP/NEXT] (B) to change

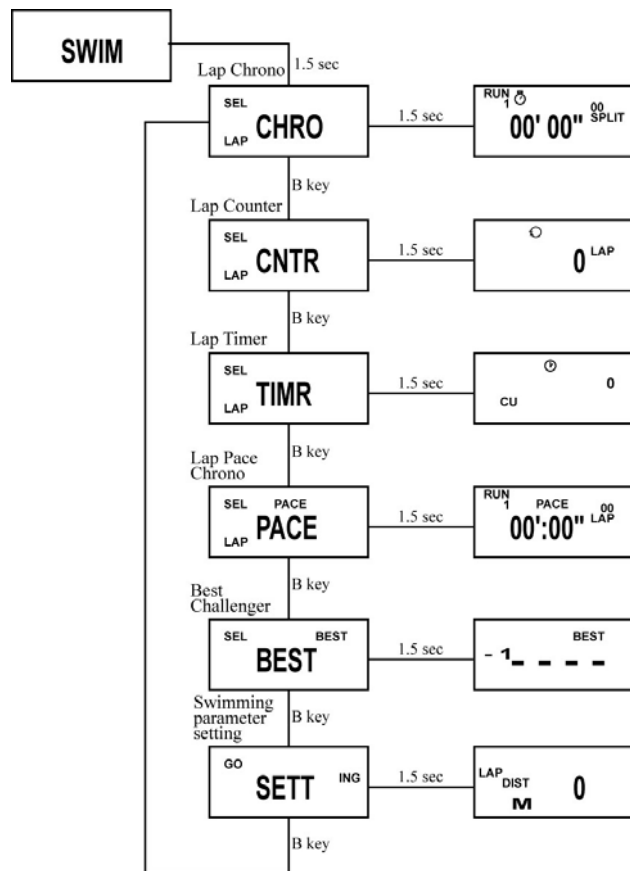

The XXL-Swim Control

Do not discard - keep the manual for future reference.

The XXL-Swim Control is provided with two suction pads (one on top and one at the bottom) for attachment to the side of the pool.

To turn on the XXL-Swim Control, press the [MODE] button at the top of the XXL-Swim Control. To turn it off, also press and hold the [MODE] button (the display may in the meantime change category) until the display goes off, with a beep.

Dual Time and Date

This function will be displayed when the XXL-Swim Control is turned on. The hour, minute, second, day of the week, month and day will be shown. The year is selected for the purpose of automatic update of the date and day of the week; it will however not be shown on the display.

You may also choose to set 2 different times (T1 & T2) - e.g. times of two cities, and either may be selected as the main time display.

Setting the Time/Date Function

1. Press and hold the [SET/RESET] button until you see 'HOLD ADJ' displayed and the display is then switched back to the time display with the hour-digits flashing.
2. Press the [START/LAP/HOLD...STOP] button (increment) or the [STOP/NEXT] button (decrement) in order to set the hour-digits.
3. When the hour of the day is set, press the [MODE] button. The minutes-digits will then flash. Now press the [START/LAP/HOLD...STOP] button (increment) or the [STOP/NEXT] button (decrement) in order to set the minute-digits.
4. When the minutes of the hour are set, press the [MODE] button. The seconds-digits will then flash. Now press either the [START/LAP/HOLD...STOP] button or the [STOP/NEXT] button in order to set the seconds-digits to 00.
5. When the seconds of the minutes is set, press the [MODE] button and the month-digits will then flash. Now press the [START/LAP/HOLD...STOP] button (increment) or the [STOP/NEXT] button (decrement) in order to set the month-digits.
6. When the month of the year is set, press the [MODE] button and the day-digits will then flash. Now press the [START/LAP/HOLD...STOP] button (increment) or the [STOP/NEXT] button (decrement) in order to set the day-digits.
7. When the day of the month is set, press the [MODE] button and the year-digits will then flash. Now press the [START/LAP/HOLD...STOP] button (increment) or the [STOP/NEXT] button (decrement) in order to set the year-digits.
8. When the year is set, press the [MODE] button and either the 24-hour or the 12-hour time mode (depending on the time mode already selected) will then appeared flashing. Now press the [SET/RESET] button to select the desired time mode.
9. When the time mode is selected, press the [SET/RESET] button to exit the setting.
10. Note that the day of the week will be automatically set according to the date and year selected. This will be displayed at the lower left corner of the device.

Setting the Dual Time Function

You will notice that either T1 or T2 is displayed below the month-day display at the upper left corner. This indicates that one of these is being used as the main time display. To view the time in the other time display, simply press the [STOP/NEXT] button and the other time display will be shown. Release the [STOP/NEXT] button to revert to the main time display. To change the main time display from T1 to T2 (or vice versa), press and hold the [STOP/NEXT] button (about 5 seconds) until you hear a beep. You will notice that the time display will then have changed from T1 to T2 (or vice versa). To set the time/date for the other time display, repeat Steps 1 - 10 above.

8-30			
T1	6	:	10 ²³
SAT			PM

8-30			
T2	3	:	10 ²³
SAT			PM

Please note that while you are in the Time/Date function, you can activate or deactivate the key tone by pressing the [START/LAP/HOLD...STOP] button located at the back of the XXL-Swim Control. If the key tone is activated, a small musical note (♪) will be displayed at the lower right corner of the display. This will disappear if the key tone is deactivated.

Swim Function

The Swim function includes the timing of your laps (Lap Chrono) for up to 50 laps, counting the number of laps (Lap Counter), counting up or down of lap time (Lap Timer), lap time comparison (Lap Pace Chrono) and the 3 best lap records (Best Challenger). The amount of calories burnt will also be shown after a lap if the lap distance and the body weight has been input into the XXL-Swim Control.

Take note that user can only choose one of the swim function at a time & change to another function when the current function is ended by reset or saved.

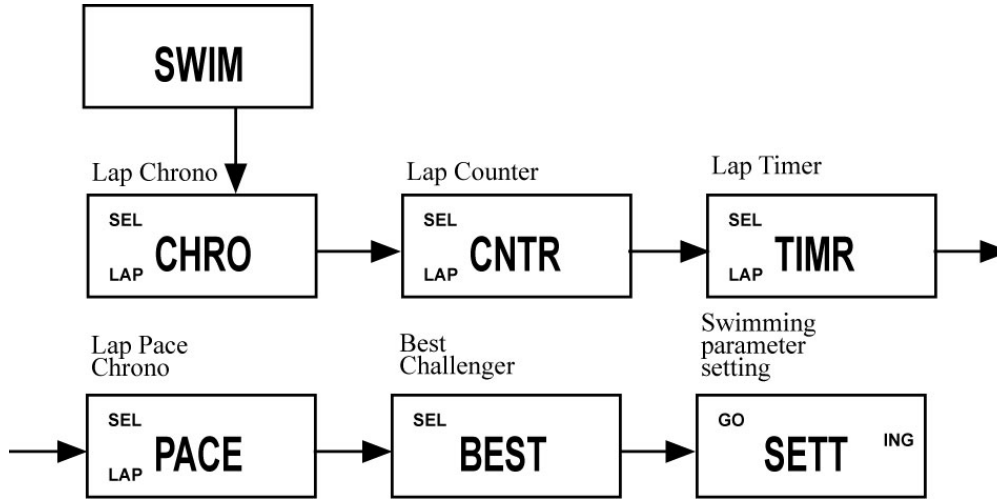

Setting of Lap Distance, Body Weight, Swimming Style and Metric/Imperial Unit

It is vital to input these data before using the XXL-Swim Control for swimming practice, otherwise calorie consumption will not be calculated.

1. First go to the Swim Function by pressing the [MODE] button.
2. Then press the [STOP/NEXT] button in order to go to the setting mode. The "Go setting" will be displayed.
3. Now press the Start/Lap/Hold...Stop button to go to the different parameters in the setting mode.

Set Lap Distance

4. Press the [START/LAP/HOLD...STOP] button until you reach the Lap Distance parameter and 'LAP DIST' is displayed.
5. Press and hold the [SET/RESET] button (about 3 seconds) until you hear a beep and see the 'Hold ADJ' displayed and then the digit flashes on the display. Now select the 2-lap* distance by pressing the [START/LAP/HOLD...STOP] button (increment) or the [STOP/NEXT] button (decrement). By pressing either the [START/LAP/HOLD...STOP] or the [STOP/NEXT] button once, the distance will go up or down respectively by one unit. If you press and hold either the [START/LAP/HOLD...STOP] or the [STOP/NEXT] button, the distance will continue increment or decrement until you release the button. The maximum distance is 500 meters or 1 mile. *Please note that the value selected is the 2-lap distance.*

Since the XXL-Swim Control will be attached to one end of the pool only, the lap distance input into device should in effect cover the distance of 2 lengths of the pool (see illustration below).

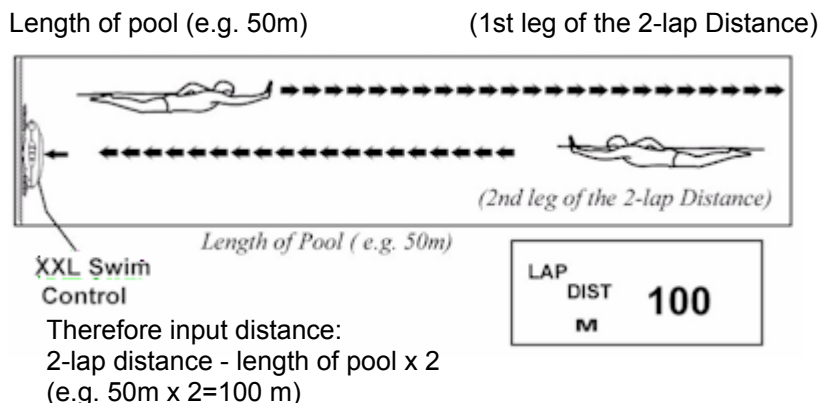

6. Press the [SET/RESET] button when you have reached the desired distance.

Set Body weight

7. Now press the [START/LAP/HOLD...STOP] button until you reach the Body Weight parameter and 'W T' is displayed.
8. Press and hold the [SET/RESET] button (about 3 seconds) until you hear a beep and see the 'HOLD ADJ' displayed and then the digit flashes on the display.
9. Now select the body weight by pressing the [START/LAP/HOLD...STOP] button (increment) or the [STOP/NEXT] button (decrement). By pressing either the [START/LAP/HOLD...STOP] or the [STOP/NEXT] button once, the weight will go up or down respectively by one unit. If you press and hold either the [START/LAP/HOLD...STOP] or the [STOP/NEXT] button, the weight will continue counting up or down until you release the button. The weight range is 0, 20-200kg or 0, 40-400LB. If 0 is set, no calorie consumption will be recorded.
10. Press the [SET/RESET] button when you have reached the desired body weight.

Set Swimming Style

11. Now press the [START/LAP/HOLD...STOP] button until you reach the Swimming Style parameter with the swimming figure displayed.
12. Press and hold the [SET/RESET] button (about 3 sec) until you hear a beep and see the 'HOLD SEL' displayed and then the swimming style flashes on the display.
13. Press the [START/LAP/HOLD...STOP] or the [STOP/NEXT] button to select the swimming style of your choice. You may select between breaststroke 'BREAST', backstroke 'BACK', butterfly 'FLY' or freestyle 'FREE'
14. Press the [SET/RESET] button to set the selected swimming style.

Select Metric/Imperial Unit

15. Now press the [START/LAP/HOLD...STOP] button until you reach the Unit parameter with 'UNT' displayed.
16. Press and hold the [SET/RESET] button (about 3 seconds) until you hear a beep and see the 'HOLD SEL' displayed and then the unit flashes on the display.
17. You may choose either Imperial 'BRITISH' or Metric 'METRIC' as the desired unit mode. Simply press the Start/ Lap/ Hold...Stop or [STOP/NEXT] button to select the desired unit, and then press the Set button to Start/ Lap/ Hold, Stop or confirm your choice.

Important: In order to be able to set the unit mode (metric or imperial), all values in the Data and the ACCM functions must be completely cleared.

Lap Chrono

This parameter records the time of your laps for up to 50 laps. These can be accumulated over several runs (when you have started and stopped the Lap Chrono after several laps, this will constitute a run; by starting the function again, you will have started another run). You can either set the number of laps to be done, in which case the Lap Chrono will stop automatically when these are reached; or you can set the number to zero, in which case you will have to stop the function manually.



1. Press the [MODE] button until you come to the SWIM function.
2. Then press the [STOP/NEXT] button to go to the Lap Chrono parameter and you see 'SEL LAP CHRO' displayed. Then it shows the timing digits after 1 second. Select location of Split/Lap press & hold the [STOP/NEXT] button until beep, the lap & split time will be interchanged.

Please note that the XXL-Swim Control offers a choice of two predominant data displays in the Lap Chrono parameter - lap time (LAP) or split time (SPLIT). Depending on your preference of display, one will be displayed on the upper left of the device, while the other will be on the right below the seconds counter. Simply press and hold for one second the [STOP/NEXT] button in order to interchange the data display of your choice.

Set Number of laps to achieve

3. Press and hold the [SET/RESET] button until you see 'HOLD ADJ' and 'NO OF LAP' displayed and the digit flashes.

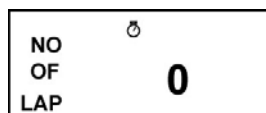

4. Now press the [START/LAP/HOLD...STOP] button (increment) or the Stop/ Next button (decrement) in order to set the number of laps desired. If the lap Chrono parameter has been run, press and hold the [SET/RESET] button to reset the data for that run.
5. Press the [START/LAP/HOLD...STOP] button to start the chrono function. The swimming animation will be activated, and the wavy progress bar at the bottom of the display will begin to appear in continuous segments until the total number of pre-set laps has been reached, at which point the entire bar will be displayed flashing and the device will beep.

Please note that after you have pressed the [START/LAP/HOLD...STOP] button, there will be a 3-second time lapse before the Lap Chrono starts to function.

6. Every time you finish a lap, press the display once to activate the [START/LAP/HOLD...STOP] button at the back. The lap time and calories burnt for that lap will then be displayed and these will automatically be registered and saved to the Data function.

You will notice that, when the Lap Chrono function is running, the total number of laps to be finished will be displayed at the lower left corner, while the lap you are on will be shown on the right below the split-second display (e.g. LAP 5).

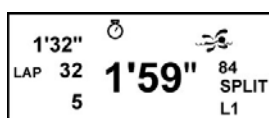

7. When you have finished the pre-set number of laps, the Lap Chrono function will stop automatically with a beeping sound and the swimming animation will at the same time stop.
8. If you have not pre-set any number of laps, you can stop the chrono function by pressing the [STOP/NEXT] button. You can use another way to stop the Chrono by press and hold the Start/Lap/Hold....Stop button for 3 seconds. *Note that in the absence of any pre-set number of laps, the wave-like progress bar at the bottom will be shifting towards the right when you start the chrono function, indicating that is in process.*
9. When you have stopped the chrono function, press and hold the [STOP/NEXT] button until you see 'HOLD RUN
10. To clear the data for that particular run, press and hold the Set/ Reset bouton after you have stopped the chrono function until you see 'HOLD
11. To review the data stored, go to Data mode. See Data Function section below for details.

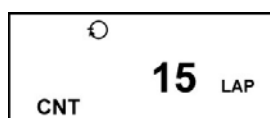

Lap Counter

This parameter records the time taken to finish a pre-set number of laps.

1. Press the [MODE] button until you come to the SWIM function.
2. Then press the Stop/ Next button to go to the Lap Counter parameter and you see ' SEL LAP CNTR' displayed. Then it shows the digits display after 1 second.
3. Press and hold the [SET/RESET] button until you see 'HOLD ADJ' and then "NO OF LAP" displayed with the digits flashing.
4. Press and hold the [START/LAP/HOLD...STOP] button (increment) or the [STOP/NEXT] button (decrement) until the desired number.
5. Press the [SET/RESET] button to set the number of laps.
6. Press the [START/LAP/HOLD...STOP] button to start the chrono function.
7. Every time you finish a lap, press the display once to activate the [START/LAP/HOLD...STOP] button at the back. The split time and number of calories burnt for that lap will then be displayed.
8. When the last lap has been completed, the Lap Counter function will stop automatically with a beeping sound. The swimming animation will stop, and the wave-like progress bar at the bottom of the display will appear flashing.
9. The time taken to finish the pre-set number of laps will be shown at the upper left corner of the display in hour, minutes, seconds and one-hundredth seconds.

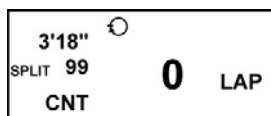

10. To reset to the same number of laps, press and hold the [SET/RESET] or [STOP/NEXT] button until you see "HOLD RSET" and then 'CNTLAP'. You can then start the Lap Counter function again by repeating Steps 4 - 7.
11. In order to use the Lap Counter function again with a different pre-set number of laps, repeat Steps 1 - 5.
12. You can also use the Lap Counter function without pre-setting any number of laps. Simply set the number of laps to 0 according to Steps 1 - 5.
13. Press the [START/LAP/HOLD...STOP] button to start the chrono function.
14. Every time you finish a lap, press the display once to activate the [START/LAP/HOLD...STOP] button at the back. The split time and number of calories burnt for that particular lap will then be displayed.
15. Press the [STOP/NEXT] button when you want to stop the Lap Counter function. You can use another way to stop the Lap Counter by press and hold the [START/LAP/HOLD...STOP] button for 3 seconds.
16. The number of laps done will be displayed on the right of the display, while the time taken to finish will be displayed at the upper left corner.

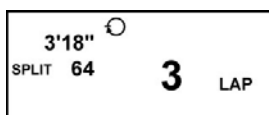

17. Repeat Step 10 to reset the Lap Counter function and steps 1-5 to pre-set number of laps to count.

Lap Timer

The Lap Timer function shows the number of laps you have done within the preset time. The number of calories burnt will also be shown if lap distance and body weight has been input into the device.

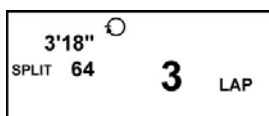

1. Press the [MODE] button until you reach the SWIM function.
2. Press the [STOP/NEXT] button until you see 'SEL LAP TIMR'. Then it shows the digit display after 1 second.
3. Press and hold the [SET/RESET] button until you see 'HOLD ADJ' and then the digits appear flashing.
4. Use the [START/LAP/HOLD...STOP] button (increment) or the [STOP/NEXT] button (decrement) in order to set the digits. Press the [MODE] button in order to move to the next set of digits (e.g. from the hour-digits to the minutes-digits, or from the minutes-digits to the seconds-digits).
5. When the desired time has been selected, press the [SET/RESET] button. The display will show 'TOTAL Cd' at the lower left corner, indicating that the time set will be running in decrement manner. The '0' just above the 'TOTAL Cd' indicates that the timer has not yet started.
6. Press the [START/LAP/HOLD...STOP] button to start the chrono function. The swimming animation will be activated and the wave-like progress bar flash at the bottom of the display will at the same time start shifting from left to right.
7. Every time you finish a lap, press the display once to activate the [START/LAP/HOLD...STOP] button at the back. The elapsed time will then be displayed at the upper left corner, followed by a display of the number of calories burnt for that particular lap.

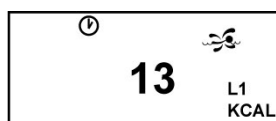

8. When the pre-set time of the Lap Timer is up, there will be a beeping sound and the wave-like progress bar will flash. You will see the number of laps you have done within the pre-set time displayed at the lower right corner (e.g. L5).

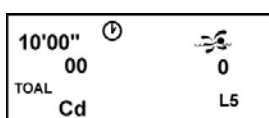

9. To reset the same pre-set time, simply press the [STOP/NEXT] button until you see 'HOLD RSET' and then same pre-set time displayed.
10. To set another pre-set time, press & hold [SET/RESET] button until you see 'HOLD ADJ' displayed.
11. Then repeat Steps 3 and 4.

You can also set the timer to 00:00'00, in which case you will have to stop the timer manually.

1. Use Steps 3 and 4 above to set the timer to 00:00'00. The display will show 'CU' at the lower left corner, indicating that the time set will be running in a increment manner. The '0' on the right of the display indicates that the timer has not yet started

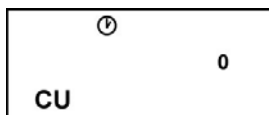

2. Press the [START/LAP/HOLD...STOP] button to start the Lap Timer function.
3. Every time you finish a lap, press the display once to activate the [START/LAP/HOLD...STOP] button at the back. The elapsed time will then be displayed, followed by a display of the number of calories burnt for that lap.

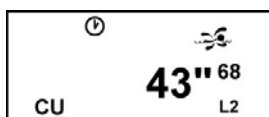

4. Press the [STOP/NEXT] button when you have finished. The time taken together with the number of laps done will then be displayed. You can use another way to stop the Lap Timer by press and hold the [START/LAP/HOLD...STOP] button for 3 seconds.

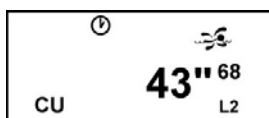

Lap Pace Chrono (PACE)

This function gives a comparison between the preset target time and the actual lap records. It can record up to a total of 50 laps which can be accumulated over a number of runs.

1. Press the [MODE] button until you reach the SWIM function.
2. Press the [STOP/NEXT] button until you see "SEL LAP PACE". Then it shows the digit display after 1 second.
3. Press the [SET/RESET] button until you see 'HOLD ADJ' displayed, followed by 'NO OF LAP' with the digits flashing.
4. Use the [START/LAP/HOLD...STOP] button (increment) or the [STOP/NEXT] button (decrement) in order to set the number of laps per run. Press the [SET/RESET] button when you reach the desired number.
5. The display will then show 'PACE TA' AND 'PACE' with flashing digits, for the setting of the target lap time



Press the [START/LAP/HOLD...STOP] button (increment) or the [STOP/NEXT] button (decrement) in order to set the target time. Use the [MODE] button to move to the next set of digits (e.g. from the hour-digits to the minutes-digits, or from the minutes-digits to the seconds-digits).

6. Press the [SET/RESET] button when you have preset the target time.
7. The display will then show the run you are on at the upper left corner, the number of laps set at the lower left corner. In the centre of the display will be the time taken per lap.
8. Press the [START/LAP/HOLD...STOP] button to start the Lap Pace Chrono function.
9. Every time you finish a lap, press the display once to activate the [START/LAP/HOLD...STOP] button at the back. The lap time for that particular lap will then be displayed, followed by the difference between the target and actual times -" d --" (your time is faster than the target time) or " d +" (your time is slower than the target time) - at the lower left corner of the display). The number of calories burnt will then be displayed as well.



10. When you have done the pre-set number of laps, there will be a beeping sound and the wave-like progress bar at the bottom will flash.
11. Stop the Lap Pace Chrono function by pressing and hold the [STOP/NEXT] button until you see 'HOLD RUN.....' in order to close the Lap Chrono mode and store the chrono time to the Data mode.
12. To clear the data for that particular run, press and hold the [SET/RESET] button after you have stopped the chrono function until you see 'RUN # RSET'.
13. To review the data stored, go to Data mode. See Data Function below for details.

The target lap time can also be set at 00:00'00, in which case every lap time will be compared with the previous lap and the difference will be shown upon every lap. The number of laps can likewise be set at '0', in which case you stop the Lap Pace Chrono manually, when you have finished your swimming practice.

Best Challenger (BEST)

This function keeps the time of the 3 best RUNS (not laps). These times are consolidated and retrieved from the Lap Chrono, the Lap Counter, the Lap Timer and the Lap Pace Chrono. On the other hand, the best record can also be input into the function manually - e.g. a world record - if you want to try to beat this.



1. Press the [MODE] button in order to go to the Swim function.
2. The press the [STOP/NEXT] button in order to go to the Best Challenger parameter.
3. Now press the [SET/RESET] button to select one of the 3 best records.
4. The distance swum will be shown on the upper left corner of the display, below which will be indicated which best record it is (e.g. - 1 is the best, - 2 the second and - 3 the third). The time taken to finish the indicated distance is shown on the right side of the display. (If the Lap distance is not set, the number of lap's forthe records will be shown instead.)



5. First select the best record against which you want to compete by pressing the [SET/RESET] button. The record chosen will then be shown on the display.
6. Now press the [START/LAP/HOLD...STOP] button to start the Best Challenge function.
7. Every time you finish a lap, press the display once to activate the [START/LAP/HOLD...STOP] button to at the back. The lap time for that lap will be shown on the right of the display, while the accumulated lap time will be shown at the top left corner. The remaining number of laps will be shown below the accumulated lap time.



8. When you have done the set number of laps, there will be beeping sound and the difference between the chosen best record and your run time will be shown through the display of 'd-' (you are faster than the best time) or 'd +' (you are slower than the best time) below the accumulated time, with the time difference on the right of the display. If your run record is better than the chosen record, the word BEST at the top will flash, indicating that you have broken the chosen best record.



9. Press the [STOP/NEXT] button to resume the chosen best record. Then press the [SET/RESET] button to choose another best record if another record is desired. The best record can also be input manually.
10. First delete any existing best record value by pressing and holding the [SET/RESET] button until you see 'HOLD CLR' on the display, and then the record disappears.
11. Press and hold the [SET/RESET] button again until you see 'HOLD SET', and the flashing digits appear.
12. Press the [START/LAP/HOLD...STOP] button (increment) or the [STOP/NEXT] button (decrement) in order to set the hour-minutes-seconds digits. Use the [MODE] button to move from one set of digits to the next set (i.e. from the hour-digits to the minutes-digits, or from the minutes-digits to the seconds-digits).
13. Repeat Steps 6 - 8.

Data Function

The Data Function records up to a total of 50 laps, which may be accumulated over a number of runs. Apart from reviewing the lap records in the Lap Chrono Mode and the Lap Pace Chrono Mode, it also shows the total time, the best lap time, the average lap time, average speed, the total distance and the total calories burnt for each run record.



1. Press the [MODE] button in order to go to the DATA function.
2. The display will then show the date and day, and indicate the run it is showing (e.g. RUN 1). Change the RUNS with [STOP/NEXT]
3. Press the Start/Lap/Hold.Stop button to go to the different parameters. These will appear in the order of
 - Target Time (for Lap Pace Chrono record)
 - Lap Pace of each individual lap
 - Total Time
 - Best Lap Time
 - AVG Time (average lap time of all the pace record)
 - S Pd (average speed of the pace record)
 - Total Distance
 - Number of calories burnt
4. If you need to clear all data (e.g. to set the metric/imperial unit), simply press and hold the [SET/RESET] button until you see 'HOLD CLR'. Repeat this procedure until all runs are cleared. The display will then show 'NO REC'.

ACCM Function

This function shows the accumulated distance and the accumulated number of calories burnt, and serves only for the recording and reviewing of data.

1. Press the [MODE] button in order to go to the ACCM function.
2. Use the [START/LAP/HOLD...STOP] button to select the item you want to see.
3. To clear both data within the function, press and hold the [SET/RESET] button until you see 'HOLD CLR'. The values displayed for both items will then become 0.

Loop Timer Function

The Loop Timer Function allows you to set the timer in 1 - 3 segments, functioning one after another - in a loop. When the first segment finishes decrement, the second segment will immediately begin to countdown. When the third segment has finished decrement, the first segment will immediately begin to countdown again. This process will go on in this manner for a maximum of 23 hours 59 minutes and 59 seconds of decrement time for each segment or a maximum of 30 loops, at which point the timer will stop automatically.

1. Press the [MODE] button in order to go to the Loop 'Timer' function.
2. Press and hold the [SET/RESET] button until you see 'HOLD ADJ' displayed. The display will then show SEG -1 with the time digits flashing.

3. Press and hold the [START/LAP/HOLD...STOP] button (increment) or the [STOP/NEXT]button (decrement) until you reach the desired digits. Use the [MODE] button to move to the next set of digits (e.g. from the hour-digits to the minutes-digits, or from the minutes-digits to the seconds-digits). Maximum can be preset to 23 hours 59 minutes 59 seconds. If the timer is preset to "0", it will not be counted.
4. Press the [SET/RESET] button to set the desired duration for the segment.
5. Now press the [STOP/NEXT]button in order to go to segment 2.
6. Repeat Step 2.
7. Press the [STOP/NEXT]button in order to go to segment 3.
8. Repeat Step 2.
9. Press the [START/LAP/HOLD...STOP] button to begin the counting down of the loop timer.
10. You may stop the timer at any time by pressing the [STOP/NEXT]button. To resume the counting down, press the [START/LAP/HOLD...STOP] button again.
11. You can reload the preset timer value for all segments by pressing and holding the [SET/RESET] button while in any segment, until you see 'HOLD RSET'.
12. Repeat Step 3 to set the values to 00:00'00, thus clearing the timer value for that segment.
13. If you want to clear the timer values for all 3 segments, preset and hold the [STOP/NEXT]button until you see 'HOLD CLR ALL', indicating that all values have been cleared.

Daily Alarm Function

In the Daily Alarm Function, you may select to set 1 - 3 individual daily alarms.

1. Press the [MODE] button in order to go to the Daily Alarm function.
2. Use the [STOP/NEXT]button to go to the different alarm segments.
3. To set the alarm for Alarm 1, press and hold the [SET/RESET] button until you see 'HOLD ADJ', followed by flashing digits.
4. Set the hour-minute digits by pressing and holding the [START/LAP/HOLD...STOP] button (increment) or the [STOP/NEXT]button (decrement) until you reach the desired hour or minutes. Use the [MODE] button to move from the hour-digits to the minutes-digits, or vice versa.
5. Press the [SET/RESET] button to set the desired alarm. This will automatically turn on the alarm and the (•••••) will be displayed.
6. To turn off the alarm, press the [START/LAP/HOLD...STOP] button and the (•••••) will disappear. The [START/LAP/HOLD...STOP] button toggles on/off of the alarm output.
7. Repeat Steps 3 - 6 for Alarms 2 & 3 as desired.
8. The 3 alarms will go off separately at the times set. Unless these are turned off manually by pressing any key, the beeping alarm will go off on its own after 30 seconds.

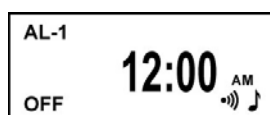

Data Memory Full Condition

Please note that the XXL-Swim Control has a memory capacity of 50 laps, on the assumption that there is only 1 run. If there are however more than 1 run, then the memory capacity will be less than 50 laps, depending on the number of runs taken. When the memory capacity of the XXL-Swim Control has been fully utilized, the word 'FULL' will be flashing at the lower left corner of the device indicating that any record thereafter will not be accumulated to the Data function.

1. If data memory is full, new lap record will not be stored in data memory. "FULL" will be flashing at the lower left corner each time after taking a lap. Delete the current run data or some more run to spare out data memory space.
2. In case there is not enough lap memory to store the whole run, the pre-set number of laps will be flashing in initial display, e.g. only 2 lap memory left out the pre-set number of lap is 4.

Installing the Battery

The XXL-Swim Control uses 2 x AAA batteries. Use only the recommended batteries.

1. The batteries compartment is located at the bottom of the XXL-Swim Control. To install/replace the batteries, unscrew the cylindrical battery compartment at the bottom of the XXL-Swim Control with the help of a coin and gently pull it out.
2. Take out the old batteries and dispose of properly.
3. Insert the new batteries, making sure that the poles are correctly placed.
4. Insert the battery compartment back into the compartment slot and screw it tightly into place.

Replacement of Battery

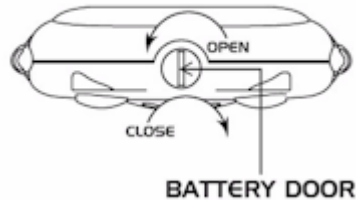

CAUTION

- Should you encounter any problems with the XXL-Swim Control (e.g. malfunctioning of a parameter, or the need to re-set the device), simply Press Reset key. All data previously input into the device would be deleted and you can then/will need to re-set the XXL-Swim Control all over again.
- The content of this manual is subject to change without further notice.
- Due to printing limitation, the displays shown in this manual may differ from the actual display.
- The manufacturer and its suppliers held no responsibility to you or any other person for any damage expenses, lost-profits, or any other claim arise by using this product.
- The contents of this manual may not be reproduced without the permission of the manufacturer